



## Forming Machine Air Consumption

Air Usage per cycle in SCFM	<b>2.685</b>
SCFM with servo driven divider fold fingers	<b>1.864</b>

## Electrical Requirements

Standard	Optional
230 VAC	460 VAC
3 Phase	3 Phase
60 Hz	60 Hz
30 Amps	15 Amps

Box I.D.	Min	Max
Length	10"	25"
Width	10"	30"
Depth	8"	16"

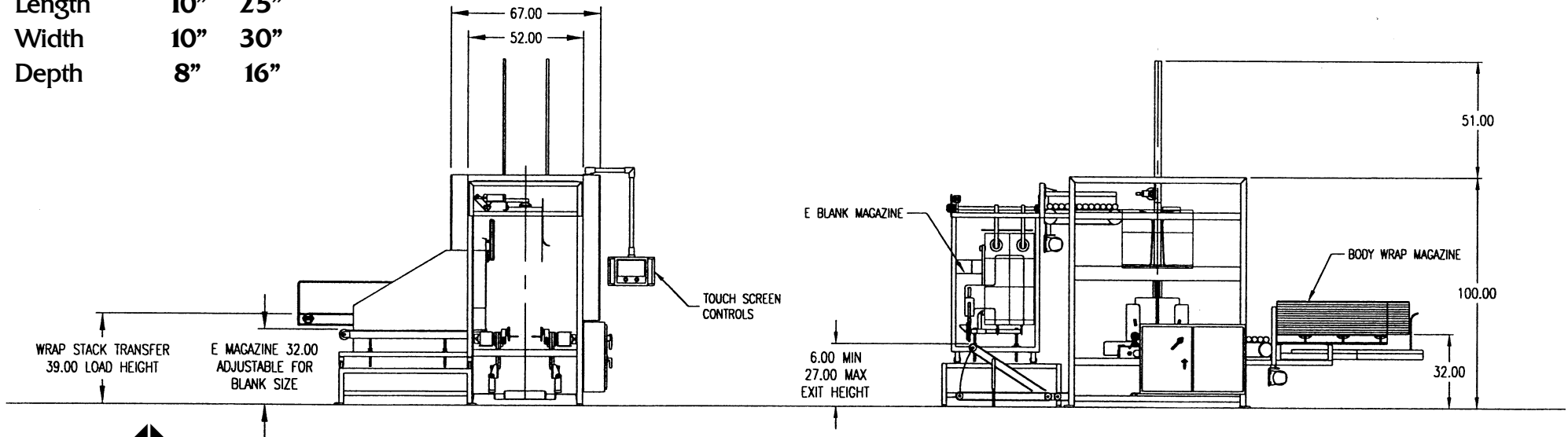
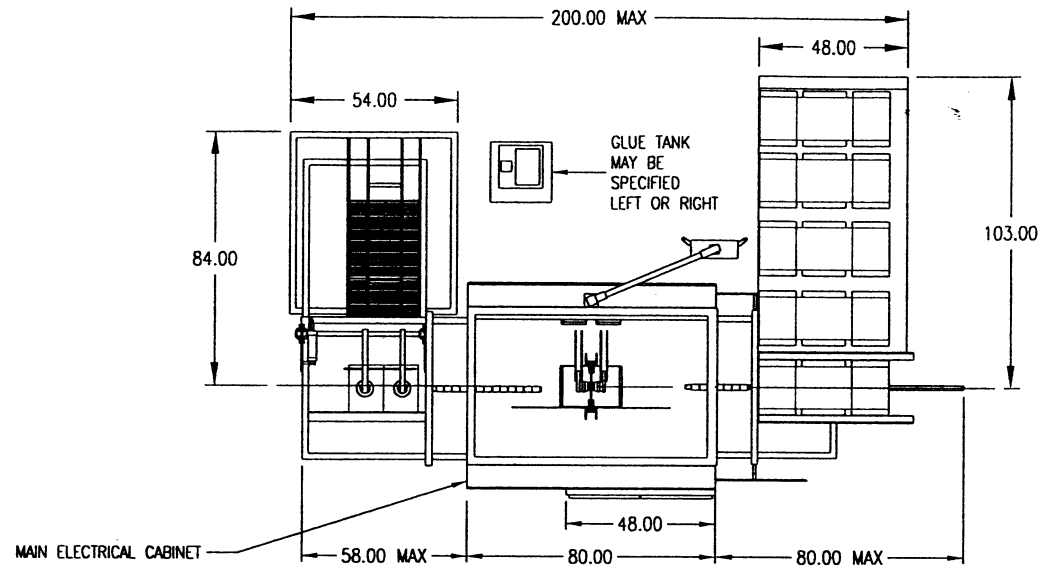

Rate of Production: Up to 20 c.p.m.

