

A | B | C | D | E | F | G | H | I

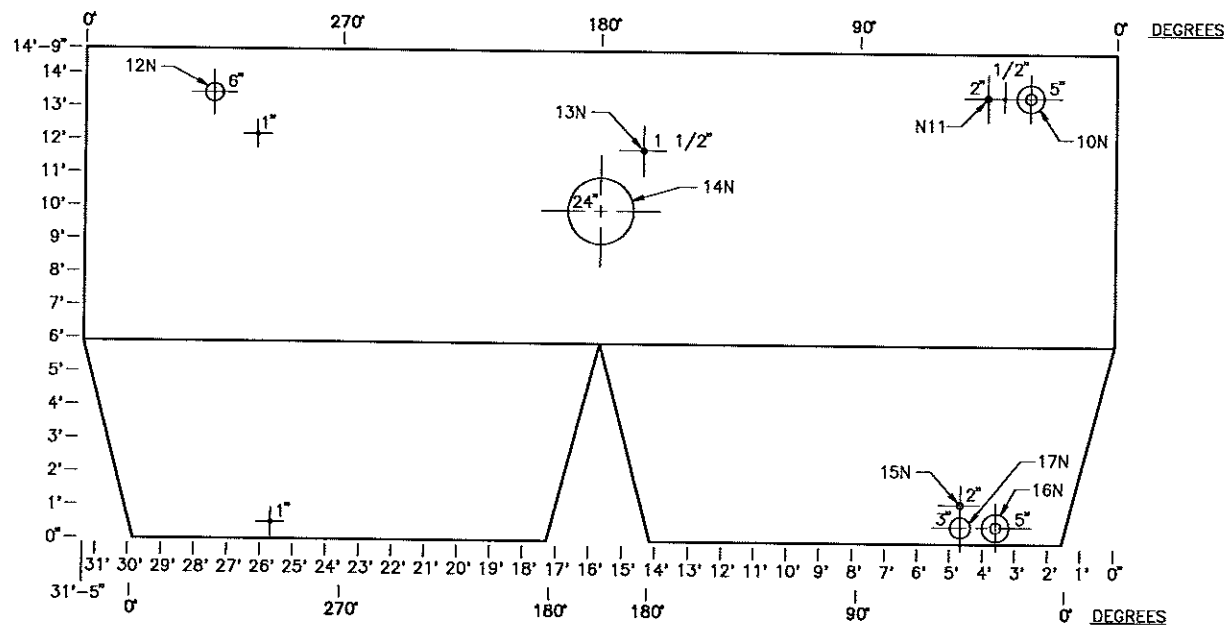
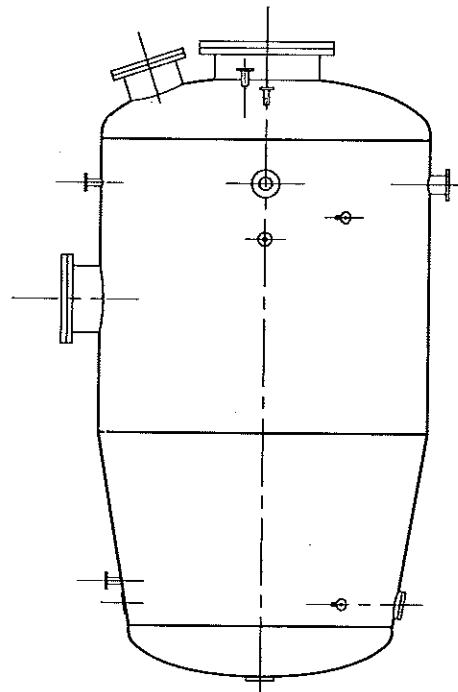
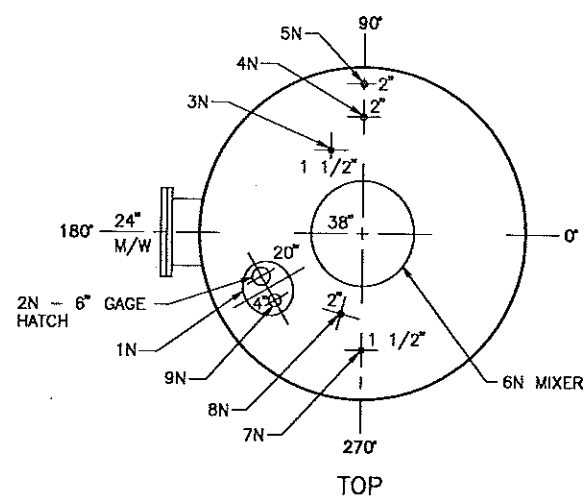
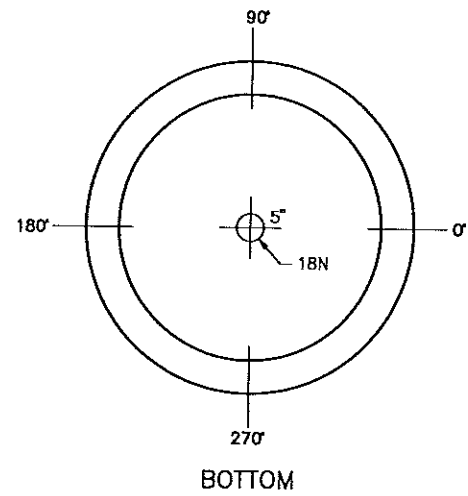

DATA SPEC.	
N.B. NO.	324
BUILT IN	1967
SHELL MATL.	316 ELC
SHELL THICKNESS	5/16"
HEADS MATERIAL	316 ELC
TOP HEAD THK'S	3/8"
BOTTOM HEAD THK'S	5/16"
PRESSURE TESTED AT	30 PSIG

VESSEL EQUIPMENT INSPECTION REPORT FOR VESSEL NO. V-1404

EQUIP. NO: V-1404	DIAMETER: 10'-0" O.D.	YEAR BUILT: 1967	TOP HEAD THK'S: 3/8"
PLANT: POLYCHEM	HEIGHT FROM TOP HEAD TO BOTTOM HEAD: 18'-0"	MTRL. TYPE: STAINLESS STEEL TYPE 316 ELC	BOTTOM HEAD THK'S: 5/16"
SERVICE: CRUDE AMINATE	CAPACITY: 8,000 GALLONS	ASME CODE 1965 SECT. VIII: YES	SHELL THK'S: 5/16"

DATE	NOZZLE
1	1N
2	2N
3	3N
4	4N
5	5N
6	6N
7	7N
8	8N
9	9N
10	10N
11	11N
12	12N
13	13N
14	14N
15	15N
16	16N
17	17N
18	18N
19	19N
20	20N
21	21N
22	22N
23	23N
24	24N
25	25N
26	26N
27	27N
28	28N
29	29N
30	30N
31	31N
32	32N
TOP HEAD	BOTTOM HEAD
1T	1B
2T	2B
3T	3B
4T	4B
5T	5B
6T	6B
7T	7B
8T	8B
9T	9B
10T	10B
11T	11B
12T	12B
13T	13B
14T	14B
15T	15B



EQUIPMENT INSPECTION REPORT  
FOR VESSEL NO. V-1404  
POLYCHEM PLANT  
RICHMOND, CALIFORNIA

SCALE NONE DATE 12-30-94 APPROVED  
DR. MEF CH. BE DR. APP. DEH ENGR. HG  
OPR'G DEPT. ENG. DEPT.

A c.c. S.O. B-69573 016  
REV SHIT

68973-16 MEF 01-27-95